

METAL DETECTOR

METRON 05 S

RELIABLE DETECTION OF ALL METALS:

- FERROUS
- STAINLESS STEEL
- ALUMINUM
- COPPER
- BRASS
-

RELIABLE DETECTION OF FREE OR ENCAPSULATED CONTAMINANTS.

Version 09/18

**SINGLE SURFACE METAL DETECTOR FOR INSTALLATION
IN BELT CONVEYORS, VIBRATORY CHUTES, ...
PREFER TO USE FOR LITTLE PRODUCT HEIGHT**



INDUSTRIES

- TEXTILE INDUSTRY
- QUARRY INDUSTRY
- TIMBER INDUSTRY
- RUBBER- AND PLASTIC INDUSTRY
- RECYCLING INDUSTRY

APPLICATION

- PRODUCT INSPECTION
- MACHINERY PROTECTION, E.G.:
- CALENDARS
- GRINDERS, CRUSHERS, MILLS
- CHIPPERS
- AND MORE

www.mesutronic.de



SCOPE OF DELIVERY

- DETECTOR HEAD
- ELECTRONICS MOUNTED IN A METAL CABINET
- CONNECTING CABLES
- INSTALLATION ACCESSORIES
- USER MANUAL INCL. INSTALLATION INSTRUCTIONS, WIRING DIAGRAM AND SPARE PARTS LIST IN SEVERAL LANGUAGES
- EG CONFORMITY DECLARATION

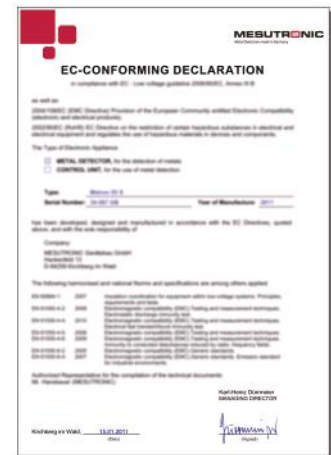

OPTIONAL EQUIPMENT

- WARNING DEVICE
 - BEACON
 - BUZZER
 - BEACON WITH SIREN
- REMOTE RESET DEVICE
- CONVEYOR CONTROLS
 - CONVEYOR REVERSE
 -
- VISUAL MARKERS
 - INK JET SYSTEM
 - BAG DROP SYSTEM
 -
- REJECT SYSTEMS
 - PUSHER SYSTEMS
 - FLAP SYSTEMS
 - CUT-OUT DEVICE
 -
- CUSTOMIZED SOFTWARE SOLUTIONS
 - SPECIAL CONTROL OPERATIONS
 - DATA TRANSFER
- POWER CONDITIONER
 - MAGNETIC VOLTAGE STABILIZER
 - ELECTRONIC VOLTAGE STABILIZER
- TURN KEY SYSTEMS CONSISTING OF CONVEYOR - DETECTOR - REJECT

SPECIAL VERSIONS

- DETECTOR HEAD AND CONTROL BOX IN STAINLESS STEEL
- EXPLOSION PROOF (PROTECTION TYPE IP 65)
- CUSTOM PAINT
- SPECIAL POWER SUPPLY
- HIGH TEMPERATURES
- ALUTRON-VERSION (NO FALSE TRIPPING BY METALLIC FILMS SUCH AS CUP LIDS,,) PATENT-NO. 4342826
- NEUTRAL DELIVERY WITH INDIVIDUAL LABELING



DIMENSIONS

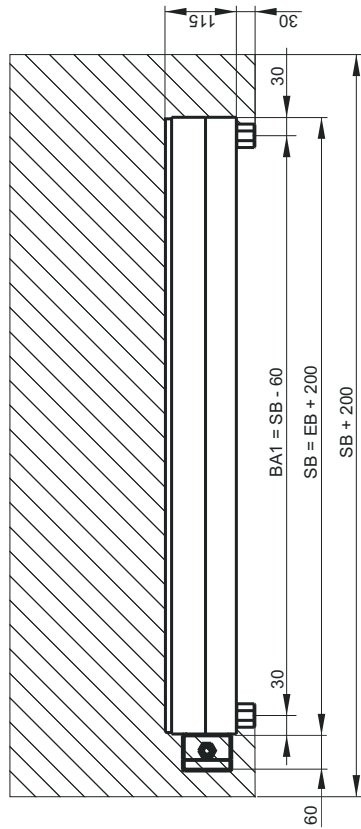
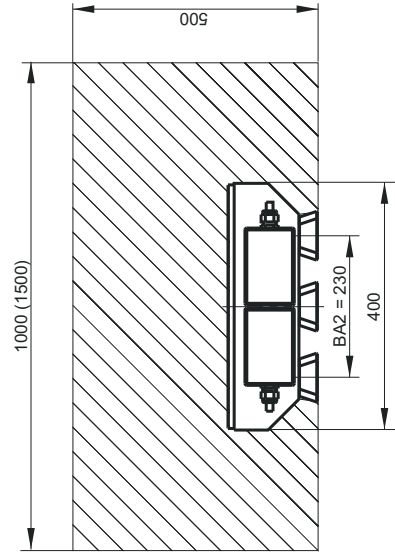
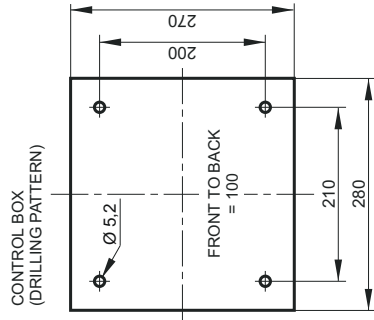

MFZ = METAL FREE ZONE FOR NON MOVING METAL

BA = DISTANCE BOREHOLE (6 HOLES PER COIL)

EB = (SENSITIVE WIDTH) FROM 200 TO 6000 MM

B = (DETECTOR WIDTH) = EB + 200 MM

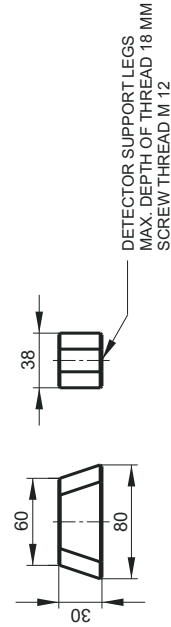

ALL DIMENSIONS IN MM.

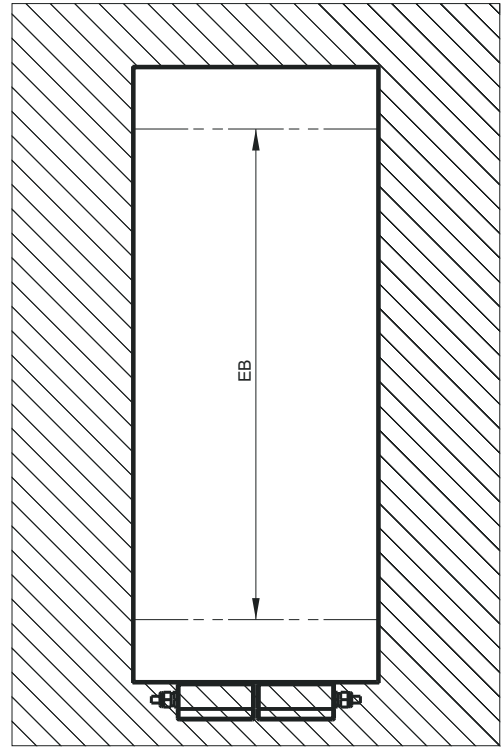

METAL FREE ZONE (MFZ)

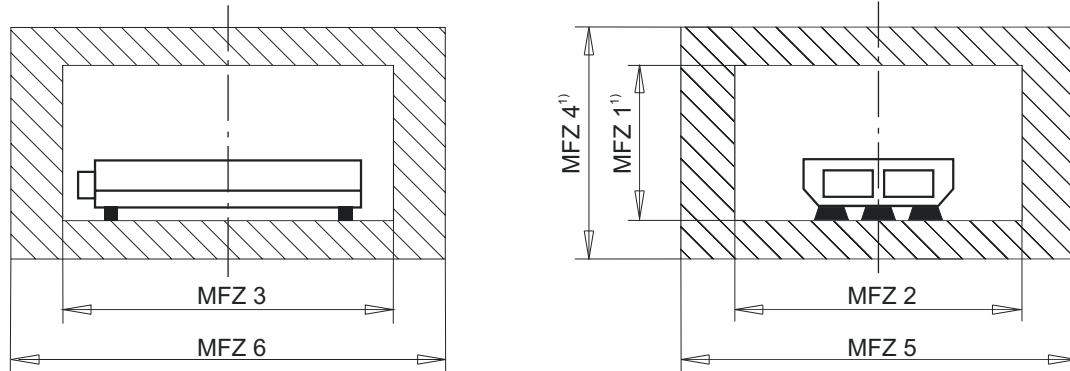

CALCULATING THE „METAL FREE ZONE“ ...

FOR NON-MOVING METALS

MFZ 1 = 500 MM
 MFZ 2¹⁾ = 1000 MM
 MFZ 3 = B + 400 MM

FOR MOVING METALS

MFZ 4 = 1500 MM
 MFZ 5¹⁾ = 1800 MM
 MFZ 6 = B + 1500 MM



¹⁾ POSITION THE DETECTOR APERTURE IN THE MIDDLE OF THE „METAL FREE ZONE“
 FOR THE OTHER DIMENSIONS: POSITION THE DETECTOR SYMMETRICAL IN RELATION TO THE APERTURE.

THE CALCULATED DIMENSIONS ARE TO BE TAKEN AS ORIENTATION VALUES (MINIMUM VALUES WHICH SHOULD BE EXCEEDED.) AND HAVE TO BE VERIFIED BY THE MANUFACTURER, DEPENDING ON THE PROJECT. MAKE THE „METAL FREE“ ZONE AS LARGE AS POSSIBLE. „NON-MOVING“ METALS ARE CONVEYOR FRAMES AND COIL SUPPORTS. (BUT NOT THE TRAVERSE CONNECTIONS BETWEEN SUCH EQUIPMENT!) MOVING METALS ARE DIVERTER AND DRIVE ROLLERS OR FOR EXAMPLE THE AXIS OF A REJECT PUSHER. PAY PARTICULAR ATTENTION TO MOVING GATES AND MACHINES OR MACHINE PARTS WHICH CHANGE THEIR DISTANCE TO THE METAL DETECTOR OR WHICH MOVE IN THE VICINITY OF THE APERTURE. IF THE METAL FREE ZONE CANNOT BE MAINTAINED DUE TO SPACE RESTRICTIONS FALSE REJECTS AND OR REDUCED SENSITIVITY CAN BE EXPECTED.

IN ADDITION, PLEASE OBSERVE OUR „ HINTS FOR THE INSTALLATION OF SEARCH COILS“.

SENSITIVITY DIAGRAM

THE SENSITIVITY DEPENDS ON THE DISTANCE FROM THE SENSING SURFACE. THE SMALLER THE DISTANCE THE GREATER THE SENSITIVITY.

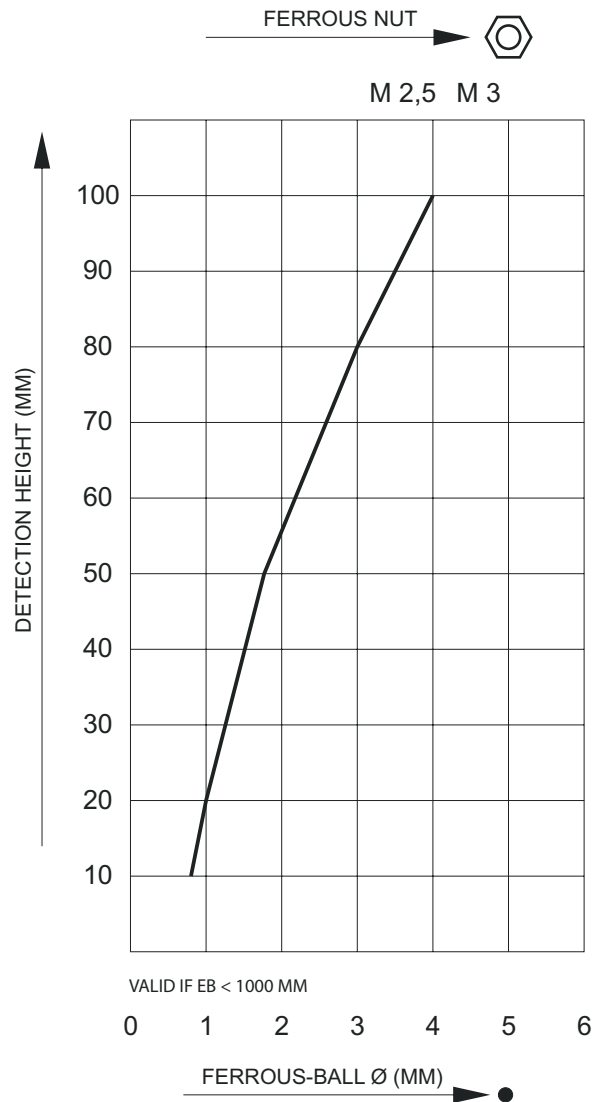

THE SENSITIVITY SHOWN IN THE ADJACENT DIAGRAM WERE ACHIEVED UNDER SIMULATED PROCESS CONDITIONS – POSSIBLE PRODUCT EFFECTS HAVE NOT BEEN CONSIDERED. IF YOU SEND US SOME PRODUCT SAMPLES, WE WOULD BE PLEASED TO DO A TEST AND QUOTE THE BEST SENSITIVITY.

TO CALCULATE SENSITIVITY FOR OTHER METALS USE THE FOLLOWING MULTIPLICATION FACTOR.

VA (STAINLESS STEEL) = FE-BALL x 1 TO 2 (FACTOR DEPENDS ON THE METAL ALLOY)
 CU, ALU, BRASS, ... = FE-BALL x 1.4 TO 1.6 (FACTOR DEPENDS ON THE METAL TYPE)

CONTROL UNIT AMD 05 (Version 5.2)

ADVANTAGES THAT WILL CONVINCE YOU!

SINGLE BOARD DESIGN WITH BUILT IN REGULATED POWER SUPPLY FOR RELIABLE PERFORMANCE AND EASE OF SERVICE.

AUTO-SETUP-ROUTINE WITH INTERFERENCE SIGNAL SUPPRESSION AND AUTOMATIC SENSITIVITY CALIBRATION.

MULTI-FILTER SYSTEM USING DIGITAL FILTRATION FOR MAXIMUM STABILITY IN HARSH ENVIRONMENTS.

AUTO-BALANCE AUTOMATICALLY DETECTS AND COMPENSATES FOR ANY CHANGES IN THE SIGNAL DURING NORMAL OPERATION. (E.G. TEMPERATURE VARIATIONS)

SELF MONITORING SYSTEM ENSURES ALL IMPORTANT COMPONENTS ARE FUNCTIONING PROPERLY. IN CASE OF A FAULT, RELAY OUTPUTS ARE AVAILABLE. FAULTS ARE DISPLAYED AS TEXT IN REAL TIME.

NARROW DETECTION ZONE PROVIDES AN ACCURATE LOCATION OF THE METALLIC PARTICLE IN THE DETECTION FIELD ALLOWING PRECISE SEPARATION.

TOUCHPAD CONTROLS MODERN DESIGN. RUGGED TOUCHSCREEN FOIL WITH ERGONOMIC CONTROLS.

4 BUTTON TOUCHPAD CONTROLS SUPPORTED BY EASY TO UNDERSTAND MENUS FAST ACCESS TO ALL OPERATING PARAMETERS. USER SELECTABLE DIALOG LANGUAGE.

5-LINE BACK-LIT LCD DISPLAY WITH METAL SIGNAL INDICATION. ADDITIONAL LED INDICATOR LAMPS ARE BUILT IN TO INDICATE METAL DETECTION OR FAULTS.

METAL COUNTER CAN BE DISPLAYED ON THE LCD SCREEN OR INTERFACED WITH A PRINTER OVER A SERIAL INTERFACE.

3-LEVEL PASSWORD PROTECTION WITH INTER-CHANGEABLE CODE NUMBERS.

METAL DETECTOR NETWORK AND REMOTE SERVICE EVERYTHING IS DO-ABLE! SEVERAL OPTIONAL SOFTWARE-PACKAGES ARE AVAILABLE. EXAMPLE: WITH THE BUILT-IN CAN-BUS-DATA PORT A NETWORK OF UP TO 125 METAL DETECTORS / SEPARATORS CAN BE OPERATED. THE UNITS CAN THEN BE REMOTE CONTROLLED AND OPERATED VIA A CENTRAL PC. ALSO REMOTE DIAGNOSIS, PARAMETER CHANGE AND SOFTWARE UPDATES VIA MODEM ARE POSSIBLE.

SERIAL DATA PORT FOR DIFFERENT TASKS. THE METAL DETECTOR IS EQUIPPED WITH 1 SERIAL DATA PORT (RS 232). HOWEVER THIS PORT IS RESERVED FOR FACTORY SERVICE ACCESS SUCH AS ADJUSTMENT DATA LOGGING, SOFTWARE UPDATES ETC.) AS AN OPTION, THIS DATA PORT MAY ALSO BE USED BY THE CLIENT (SWITCHABLE). IT CAN BE USED TO DRIVE A LOCAL OR CENTRAL PROTOCOL PRINTER. THE PROTOCOL LAYOUT CONFORMS TO ISO 9000 AND HACCP GUIDELINES. BI-DIRECTIONAL DATA COMMUNICATION WITH CUSTOMER'S SPS OR PC SYSTEMS IS AVAILABLE (OPTIONAL SOFTWARE PACKAGE).



ACTIVE QUALITY ASSURANCE WITH SMD COMPONENTS SAVE NOT ONLY SPACE BUT ALSO ASSURE OPTIMUM QUALITY AND SAFETY FOR THE END USER. WITH AUTOMATED PLACEMENT COMPONENT ERRORS ARE ELIMINATED. IN ADDITION EACH CARD IS 100% TESTED AND ARTIFICIALLY AGED. ALL MESUTRONIC PRODUCTS ARE DEVELOPED UNDER DIN, EN AND UVV STANDARDS AND COMPLY WITH THE STRICT CE STANDARDS AS WELL.

PRODUCT STORAGE MEMORY BACKUP FOR UP TO 500 INDIVIDUAL PRODUCTS. EACH PRODUCT HAS A COMPLETE SET OF ADJUSTMENT DATA ASSIGNED, SUCH AS SENSITIVITY, REJECT TIME ETC. THE DISPLAY OF TIME RELEVANT DATA IS IN REAL-TIME. INDIVIDUAL PRODUCT NAMES CAN BE STORED AS WELL.



mesutronic

CONTROLS

EXAMPLE OF AN INPUT DISPLAY (DEPENDING UPON THE SELECTED MENU THE DISPLAY SHOWS DIFFERENT FUNCTIONS !)

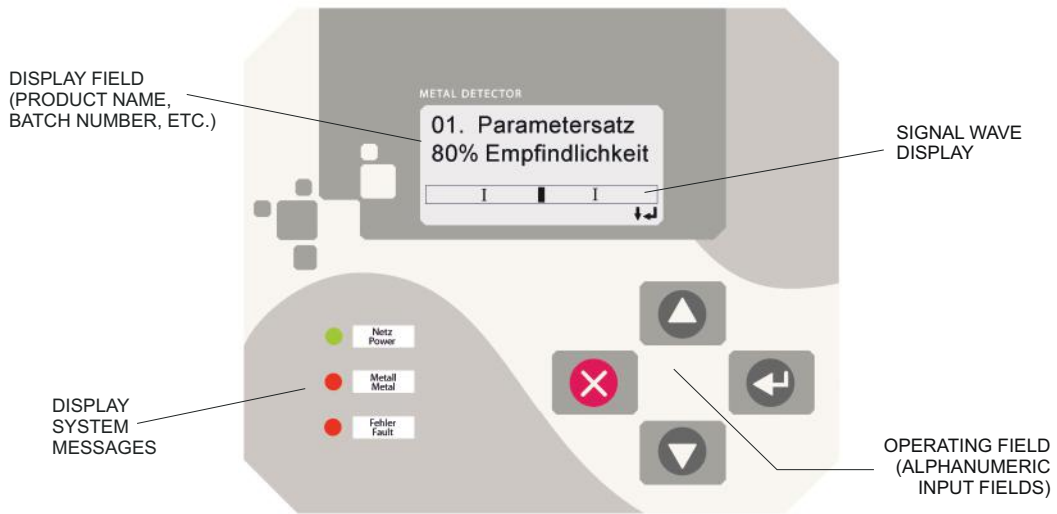

ELECTRONIC BOX

AMD 5.2

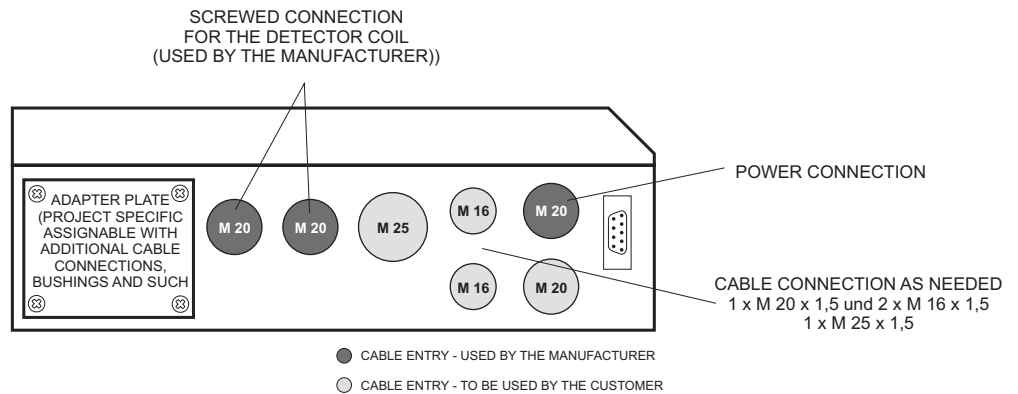

TECHNICAL DATA

POWER SUPPLY:	100 – 240 V AC, 50/60 HZ
POWER CONSUMPTION:	MAX. 50 W
FUSE:	1,25 A (SLOW BLOW); 5 X 20 MM ACCORDING TO DIN
TYPE OF PROTECTION:	IP 54
WORKING TEMPERATURE RANGE:	-10 °C TO +50 °C
STORAGE TEMPERATURE RANGE:	-10 °C TO +60 °C
REL. HUMIDITY:	0 - 90 % (WITHOUT CONDENSATION)
CONVEYING SPEED:	0,05 TO 1,5 M/SEC. (FASTER SPEED ON REQUEST)
PAINT:	RASPBERRY RED = RAL 3027
MATERIALS:	DETECTOR HEAD AND CONTROL BOX MADE OF CARBON STEEL (ST 37), SENSOR AREAS MADE OF DUROPLEX
INTERCONNECTING CABLES:	DETECTOR COIL / CONTROL BOX = 2 M LONG
POWER CABLE:	APP. 1,8 M CABLE WITH PLUG (TWO POLE AND EARTHING PIN) (US-VERSION WITH US-STANDARD PLUG)

OTHER VERSIONS AVAILABLE

LAYOUT AMD 05

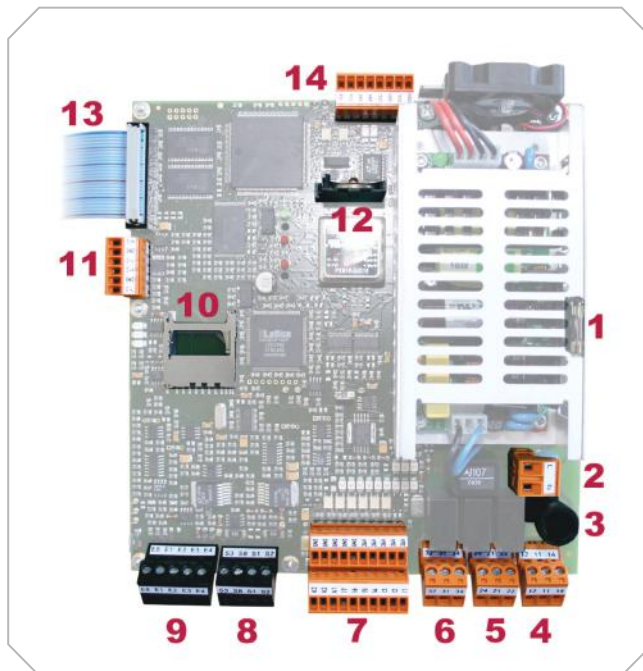

- 1.** SPARE FUSE
- 2.** POWER SUPPLY 100 - 240 VAC, 50/60 HZ
- 3.** DEVICE FUSE 1,25 A (SLOW BLOW) 5 x 20 MM ACCORDING TO DIN

- 4.** RELAY 1 (SWITCHES NORMALLY ON METAL)
 POTENTIAL FREE CONTACT
 FROM FACTORY (IF NOT REQUESTED OTHERWISE)
 RELAY 1 IS DESTINATED AS METAL-RELAY
 MAX. CONTACT LOAD: 250 V/3 A



- 5.** RELAY 1 (SWITCHES NORMALLY ON OPERATION)
 POTENTIAL FREE CONTACT
 ASIDE FROM THE OPTICAL DISPLAY A POTENTIAL FREE CONTACT IS AVAILABLE TO POLL THE UNIT CONDITION
 MAX. CONTACT LOAD: 250 V/3 A



- 6.** RELAY 3 (TO BE CONFIGURED BY THE MANUFACTURER)
 POTENTIAL FREE CONTACT
 MAX. CONTACT LOAD: 250 V/3 A

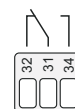

LAYOUT AMD 05

- 7.** SEVEN (7) FREE PROGRAMABLE INPUTS (24V DC)
AND THREE (3) FREE PROGRAMABLE OUTPUTS (24V DC)

In1 - INITIATOR / BUTTON „NORMAL POSITION“
In2 - INITIATOR / BUTTON „EJECT POSITION“
In3 - AIR PRESSURE MONITOR (PRESSURE SWITCH)
In4 - INPUT LIGHT BARRIER
In5 - POSITION SENSOR
In6 - EXTERNAL RESET BUTTON
In7 - NOT CONNECTED

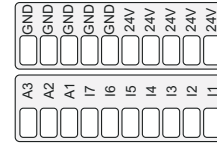

THREE (3) FREE PROGRAMABLE OUTPUTS (24V DC)
OUTPUTS (STANDARD LAYOUT)
OUT 1 - 24 V OUTPUT METAL
OUT 2 - 24 V OUTPUT READY
OUT 3 - NOT CONNECTED

ADDITIONAL CONTACT POSSIBILITIES: LEVEL SENSORS AND MORE

MAX. LOAD FOR ALL INPUTS AND OUTPUTS $I_{TOTAL} \leq 300 \text{ MA CUMULATIVE!}$

- 8.** CONNECTION SENDER (USED BY FACTORY)
9. CONNECTION RECEIVER (USED BY FACTORY)
10. SLOT FOR SD MEMORY CARD
11. CAN – BUS DATA PORT
12. BATTERY
13. CONNECTION DISPLAY (USED BY FACTORY)
14. SERIAL DATA PORT (USED BY FACTORY)

MESUTRONIC Gerätebau GmbH

A TEAM OF SPECIALISTS DEDICATED TO DEVELOP, MANUFACTURE AND MARKET THE WORLD'S FINEST ELECTRONIC METAL DETECTION AND SEPARATION EQUIPMENT FOR ALL INDUSTRIES. IT IS OUR GOAL TO PROVIDE THE OPTIMUM SOLUTION TO MEET EVERY CRITERIA. MANY YEARS OF EXPERIENCE PROVIDING HUNDREDS OF DETECTION COILS WITH VARIOUS CONTROLS AS WELL AS A MULTITUDE OF MECHANICAL SEPARATING AND SORTING COMPONENTS ARE AT YOUR DISPOSAL. WE POOL OUR KNOWLEDGE AND EXPERIENCE TO OFFER A SOLUTION TO VIRTUALLY ANY APPLICATION.

„WHEN OTHERS SAY NO, WE SAY LETS GO!“

LET OUR TEAM PROVIDE YOU WITH THE OPTIMUM SOLUTION FOR YOUR METAL CONTAMINATION.

© Copyright MESUTRONIC Gerätebau GmbH, Germany

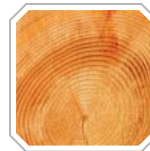
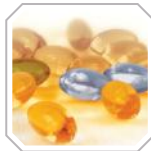

MESUTRONIC Gerätebau GmbH • Hackenfeld 13 • D-94259 Kirchberg, Wald
Tel.: +49- (0)9927 / 9410-0 • Fax: +49- (0)9927 / 1732
E-Mail: sales@mesutronic.de • www.mesutronic.de

